

Analysis of Antenna Types on the Effect of GSM Module Signals as Remote Vehicle Safety

Mira Esculenta Martawati^{1*}, Fatkhur Rohman²⁾, Arif R Fachrudin³⁾ Muhammad Ibban Utama Bhakt⁴⁾,
1,2,3,4 Politeknik Negeri Malang, Indonesia

Corresponding Author  mmilla20@gmail.com

ABSTRACT

The National Police revealed that in 2018 there were 165,918 cases of crime in Indonesia, with 19,380 cases of theft due to the lack of additional safety in vehicles. Thus, remote vehicle safety is needed to turn off the vehicle in the event of an act of theft. However, this remote security is still difficult to work if the signal quality from the BTS is weak. Because it needs a signal amplifier in the GSM module. The purpose of this paper is to analyze the effect of the GSM module signal on the injector response time as an android-based long-distance vehicle safety. The signal booster is useful so that this long-distance vehicle safety can work properly when the signal quality from the BTS is weak. The research method used is the two-way Anova method. There are two independent variables, namely: (1) BTS signal quality; (2) the antenna material is copper and aluminum. The dependent variable uses the injector response time. The test results show that in testing the BTS signal quality, copper antennas have the fastest response time compared to aluminum antennas. -60 dBm is 4.402 second and -113 dBm is 5.472 second. The conclusion of this study is that copper antennas respond faster than aluminum antennas, because copper has a higher conductivity than aluminum.

Keywords: *Vehicle Safety, GSM Module, Remote Vehicle Safety*

Journal Homepage <https://ojs.staialfurqan.ac.id/alqiyam>

This is an open access article under the CC BY SA license

<https://creativecommons.org/licenses/by-sa/4.0/>

Published by Sekolah Tinggi Agama Islam (STAI) Al-Furqan Makassar

INTRODUCTION

Vehicles are currently developing and becoming a trend in the automotive world. Vehicle manufacturers are currently competing in developing security features. However, the theft of vehicles is still happening. The following is the National Police registration data revealing that the incidence of crime in Indonesia during the 2015-2018 period is in table 1. In the data on motor vehicle theft that occurred in 2015 as many as 105,303,318 cases, in 2016 as many as 112,205,711 cases, in 2017 as many as 118,922. 708 cases and in 2018 as many as 126,508,776 cases [17] Therefore, it is necessary to have better vehicle safety so that vehicles can be controlled remotely

Table 1 Crime Data in Indonesia 2015-2018

Jenis Kendaraan Bermotor	2011	2012	2013	2014	2015	2016	2017	2018
Mobil Penumpang	--	--	--	--	12 304 221	13 142 058	13 988 202	14 830 698
Mobil Box	--	--	--	--	196 306	204 512	213 359	222 972
Mobil Barang	--	--	--	--	4 145 857	4 326 731	4 540 902	4 797 254
Sepeoda motor	--	--	--	--	88 956 931	94 531 510	100 200 245	106 657 952
Jumlah	--	--	--	--	105 303 318	112 205 711	118 922 708	126 508 776

Source: Central Bureau of Statistics

From previous research by Dewi [3], about remote car safety via SMS (Short Message Service) can turn off the starter and ignition simultaneously. However, this can endanger thieves and other motorists when the vehicle is traveling at high speed and suddenly the vehicle's ignition system is turned off, then the vehicle will stop suddenly and will result in an accident. With this problem, the author makes a long-distance vehicle safety by turning off the injector as a vehicle safety. This injector can be controlled by turning it off at the same time so that the delay can be adjusted. In this study, an antenna was added as a signal amplifier to strengthen signal reception from BTS (Base Transceiver Station). This signal booster is useful for optimizing the performance of the GSM (Global System for Mobile) module in capturing signals from cellular operator BTS. The existence of this antenna is very helpful for vehicle safety when the vehicle is in a location where the network from the BTS (Base Transceiver Station) is weak, so it can still function to turn off remotely via an Android smartphone as a remote.

METHOD

Block Diagram

The following is a block diagram of a remote vehicle safety device using an Android phone as a control

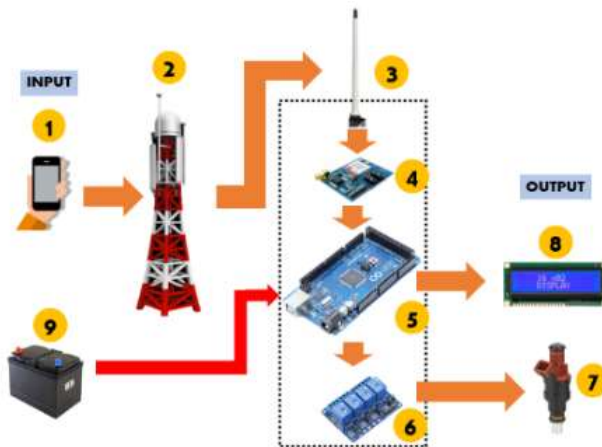

Figure 1 Block diagram

Block Diagram Description:

- 1) Android Smartphone
- 2) BTS
- 3) Antenna
- 4) GSM Module
- 5) Arduino Mega
- 6) Relay
- 7) Injector
- 8) LCD
- 9) Aki

Variable

There are several variables to be analyzed, some of which are:

1. The independent variable (independent variable)
The independent variable in this study is the signal quality of the BTS (-60 dBm to -113 dBm). The antenna materials used are copper and aluminum.
2. The dependent variable (dependent variable)
The dependent variable in this study is the injector response time.

The method used in data analysis using the two way Anova method.

RESULT AND DISCUSSION

Antenna Design

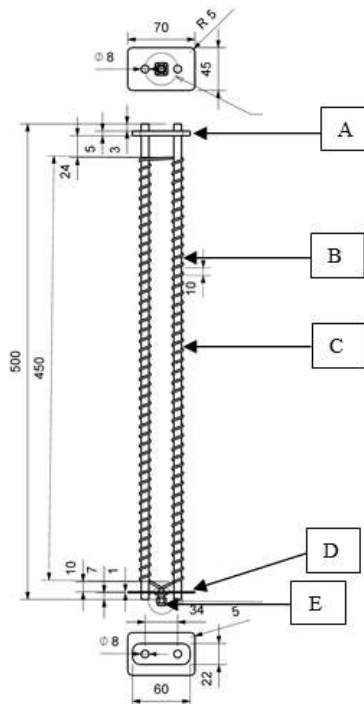

Figure 2 Antenna design

The Helix antenna uses (B) copper and aluminum wire, which is wrapped around (C) aluminum pipe, aluminum plate as (D) ground plane, (E) SMA female connector, (A) acrylic aluminum pipe fastener.

Electronic Design

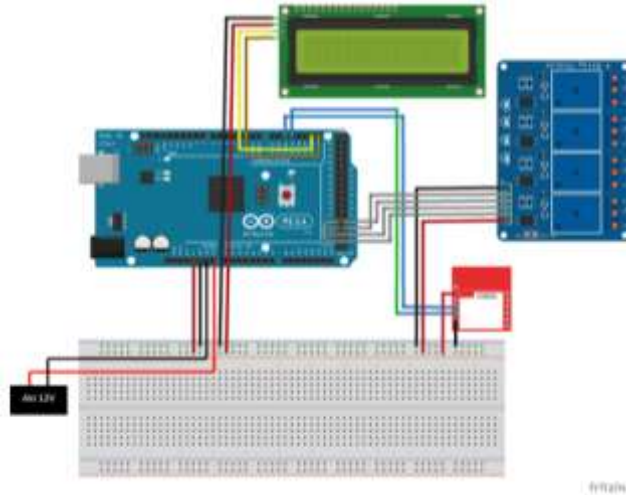

Figure 3 Electronic design

In this electronic design the power supply used is 12 volts and on the Arduino, the pin used is Vin (+) while (-) is GND. The 800L SIM pin used is the VCC to the 5 volt Arduino pin, the RXD pin to the D17 RX2 pin on the Arduino, the TXD pin to the D16 TX2 pin on the Arduino and the GND pin to the GND pin. 16x2 LCD using I2c module, the I2c output pins include; (1) VCC to 5 volt pin; (2) SDA pin to Arduino SDA pin; (3) SCL pin to Arduino SCL pin; (4) GND pin to GND pin. On the relay as the output of the Arduino command, the type used is 4 channels, the pins used include; (1) GND pin to GND pin; (2) pin IN1 to pin D49; (2) pin IN2 to pin D48; (3) pin IN3 to pin D47; (4) pin IN4 to pin D46; (5) VCC pin to 5 volt pin.

C. Programming

In the process of making the program carried out on the Arduino software. In the process, it functions to create a program for vehicle safety devices and this program will be uploaded so that the program is embedded in the Arduino Mega 2560.

```
GPS_SMS | Arduino 1.6.9
File Edit Sketch Tools Help

GPS_SMS

#define dbg Serial
#define GPS Serial1
#define SIM900 Serial3
#define RELAY1 47
#define RELAY2 49
#define RELAY3 51
#define RELAY4 53
#define INDICATOR 13

#define BUFFER_SIZE 450
#define tumboll 10

LiquidCrystal_I2C lcd(0x3F, 2, 1, 0, 4, 5, 6, 7, 3, POSITIVE);
char OKm[] = "OK\r\n";
char tm[] = "12:00";
char buffer[BUFFER_SIZE];
char buffer_GPS[BUFFER_SIZE];
int packet_len, store_index, tumbol_mode=0, count=0, time;
unsigned long timestamp;
String tempstring, alt, signal_gps;

Invalid library found in C:\Program Files (x86)\Arduino\libraries\
Arduino/Genome Mega or Mega 2560, ATmega2560 (Mega 2560) on COM4
```

Figure 4 Arduino program coding

D. Testing Tool

Testing tools are tested directly on vehicles, both motorcycles, and cars that use the EFI system.



Figure 5 Testing tools on vehicles

E. Research Analysis

Homogeneous Test

Table 2 Homogeneous Test

Levene's Test of Equality of Error Variances^b

F	df1	df2	Sig.
1.086	107	432	.282

Based on table 2, the output of SPSS is obtained by the value of Sig. of 0.282. Because of the value of Sig. $0.282 > 0.05$, it can be concluded that the variance of the response variables is homogeneous. So that the assumption of homogeneity in the two-way ANOVA test is fulfilled.

Test of Between-Subjects Effects

Table 3 Test of Between-Subjects Effects

Tests of Between-Subjects Effects

Dependent Variable: respon

Source	Type III Sum of Squares	df	Mean Square	F	Sig.
Corrected Model	36.703 ^a	107	.343	6.153	.000
Intercept	14463.815	1	14463.815	259432.865	.000
dbm	34.934	53	.659	11.823	.000
antena	.983	1	.983	17.632	.000
dbm * antena	.786	53	.015	.266	1.000
Error	24.085	432	.056		
Total	14524.602	540			
Corrected Total	60.788	539			

a. R Squared = .604

From this output is:

1. Obtained the value of sig. of $0.000 < 0.05$, so it can be concluded that "there is a difference in response based on the quality of the dBm signal".
2. Obtained the value of sig. of $0.000 < 0.05$, so it can be concluded that "there is a difference in response based on the type of antenna material".
3. Obtained the value of sig. of $1,000 > 0.05$, it can be concluded that "there is no difference in the quality of the dBm signal with the type of antenna material in determining the response speed.

Output R square = 0.604 (60.4%). This shows that 60% of the variation in the dependent variable (Y) can be explained by 2 independent variables (X1 and X2), meaning that the effect of the independent variable on changes in the dependent variable is 60.4%, while the remaining 39.6% is influenced by other variables.

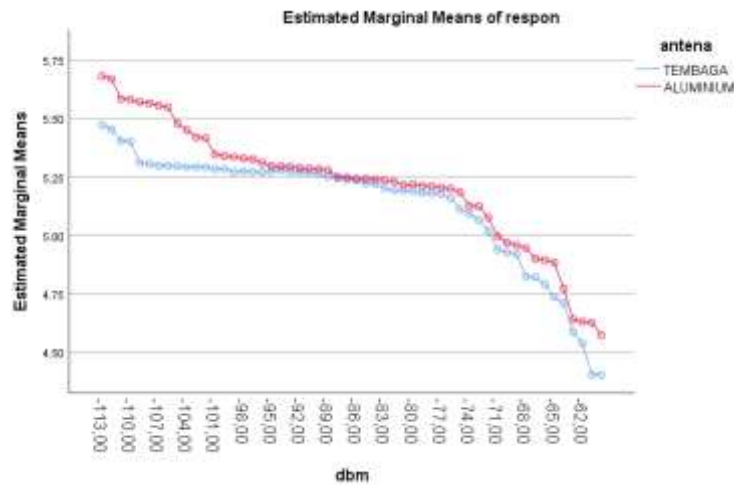

Figure 6 Antenna graph and signal quality on response speed

From the graph in Figure 6, it can be concluded that of the two antenna materials the fastest average response time is to use a copper antenna with a response speed of 4.402 seconds. The result of the graph is that copper has a higher conductivity than aluminum. The conductivity of a material is a measure of the ability of a material to conduct heat (thermally) (Holman, 1995). Materials that have a large thermal conductivity value are good conductors and vice versa, materials that have low conductivity are poor conductors.

Table 4 Thermal conductivity

Bahan	k (W/m.K)
Besi	73
Kuningan	109,0
Aluminium	205,0
Tembaga	385,0
Perak	406,0

Sumber: Zemansky, 2002

CONCLUSION

Based on the results of the tests and analyzes that have been carried out, it can be concluded that the antenna material from copper responds faster than the material from aluminum. At -60 dBm using a copper antenna, the response speed is 4.402 seconds while using an aluminum antenna the response speed is 4.572. At -113 dBm using a copper antenna, the response speed is 5.472 seconds while the aluminum antenna has a response speed of 5.682 seconds. So to produce a faster response speed, it must replace materials that have a high conductivity value.

REFERENCES

- Artiyasa, M.; Gumilar, S. & Sunarto, A. A. (2015). Rancang Bangun Antena Helix dan Simulasi dengan Software Mmanagal untuk Aplikasi Penguat Sinyal. *Jurnal Rekayasa Nusaputra*, Vol 1 No 1.
- Badan Pusat Statistik. Statistik Kriminal 2016. ISSN:2089.5291. Jakarta: Badan Pusat Statistik.
- Dewi, I. R. (2012). *Tele Alarm And Multilevel Security System On A Car Based On Arduino*. Jurnal Universitas Gunadarma.
- Duffy, James E. 1989. *Auto Electricity, Electronics, Computers*. Illinois, South Holland: The Goodheart-Willcox Company, INC.
- Dwijayatno, F. M.; Chrisyono, Y. & Santoso, I. (2014). Perancangan Antena Helix untuk Meningkatkan Daya. *Jurnal Teknik Elektro UNDIP*, Vol 3 No 4.
- Holman, J.P. (1995). *Perpindahan Kalor*. Jakarta: Erlangga.
- Kadir, A. (2015). *From Zero to A Pro Arduino*. Yogyakarta: CV. Andi Offset.
- Mahmudy, M. H.; Setijadi, E. & Hendrantoro. (2012). Desain Antena Helix dan Loop pada Frekuensi 2.4 GHz dan 430 MHz untuk Perangkat Ground Station Satelit Nano. *Jurnal Teknik ITS*, Vol 1 No 1.
- Tim EMS. (2012). *Paduan Cepat Pemrograman Android*. Jakarta: PT. Elex Media Komputido.
- William, S. (2007). *Komunikasi & Jaringan Nirkabel*. Jakarta: Erlangga.
- Winarno, E. ST M.Eng; Zaki, A. & Community, S. (2012). *Hacking & Programming dengan Android SDK unutup Advance*. Jakarta: PT. Elex Media Komputido.
- Zemansky, Mark W dan Dittman, R.H. (1986). *Kalor dan Termodinamika*. Bandung: ITB.
- <http://indo-ware.com/produk-2235-modul-relay-1-indoware.html>